

INSTRUCTION FOR UNILET SEALING FITTINGS APPROVED FOR USE WITH: APPLETON Kwiko® A AND CROUSE-HINDS Chico® A SEALING CEMENT

- The National Electrical Code in Article 501 Section 501.15 Class I, Division 1 and 2, requires that seals be installed in specific locations. This is to prevent the passage of gases, vapors or flames through the conduit from one portion of the electrical installation to another portion.
- Appleton sealing unilets are UL listed for use in hazardous locations with Appleton Kwiko A compound or Crouse Hinds Chico A compound only. These compounds, when properly mixed and poured, hardens into a dense and strong mass which is insoluble in water, is not attacked by petroleum products and is not softened by heat.
- The following sealing fitting series are UL listed for use with Appleton Kwiko A or Chico A sealing compounds:
EYF, EYF-AL, EYM, EYM-AL, EYDM, EYDM-AL, EYD, EYS, EYSF, EYSF-AL, EYSM, EYSM-AL, ESUF, ESUM

WARNING:

Failure to follow safety instructions may cause ignition of hazardous atmosphere resulting in serious personal injury and / or property damage.



Mineral Fiber Filler "Asbestos Free"



"Asbestos Free" Sealing Cement. Be sure to read the mixing instructions on Sealing cement can.

STEP 1.

Install unilet and pull conductors through.

- Remove plug(s) from sealing fitting and use fiber filler to make dam (s) in hub(s).

STEP 2.

DAMMING: Separate each conductor and pack fiber filler tightly into hub(s) behind conductors and around each conductor.

- These conductors **must not touch each other** nor the sealing fitting wall.
- Clean fiber shreds away from walls or conductors to prevent them from causing flame and / or leakage of gases. Finished dam must be flush with conduit hub bushing.

CAUTION

Refer to Table 1 to determine the maximum number and size of conductors allowed in a seal. (Page 4)

STEP 3.

Mixing: Prepare sealing compound using a completely clean mixing vessel in each batch. Shake the sealing cement thoroughly in all directions. Mix sealing cement with correct proportion of clean water as noted below.

APPLETON Kwiko A and CROUSE-HINDS Chico A CEMENT. Add one (1) part water to two (2) parts cement by volume. Use cold water, warm water increases setting speed. Add water and stir immediately and thoroughly.

- **DO NOT** mix more than can be poured in 15 minutes after adding water.
- These cements are **NOT INSULATING COMPOUNDS** and **MUST NOT** be used for such purposes.

CAUTION: TEMPERATURE/CURE TIME

APPLETON Kwiko A and CROUSE-HINDS Chico A CEMENT

FOR GROUPS C AND D APPLICATIONS: Sealing compound to be mixed **ONLY** at temperatures above 35° F (1.7° C) and **ONLY** poured into fittings that have been brought to a temperature above 35° F (1.7° C). Seals must **NOT** be exposed to temperatures below 35° F (1.7° C) for a least 8 hours. Compound must be allowed 8 hours to cure to full strength before energizing system.

FOR GROUPS A AND B APPLICATIONS: Sealing compound to be mixed **ONLY** at temperatures above 40° F (4.4° C) and **ONLY** poured into fittings that have been brought to a temperature above 40° F (4.4° C). Seals must **NOT** be exposed to temperatures below 40° F (4.4° C) for a least 72 hours. Compound must be allowed 72 hours to cure to full strength before energizing system.

STEP 4

VERTICAL CONDUIT RUN. Pour sealing cement mixture into the small pipe opening until the cement is level with the last thread of the opening. Replace and tighten small pipe plug.

HORIZONTAL CONDUIT RUN. Pour sealing cement mixture into the unilet through the large opening until two (2) to three (3) threads are covered with the cement.

- Replace and tighten in sequence the large pipe plug or cover the small pipe plug into the unilet and the small pipe plug into the cover.

Damming and Pouring:

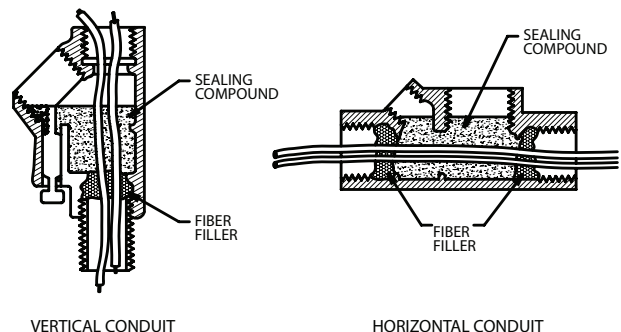

VERTICAL CONDUIT

HORIZONTAL CONDUIT

SEALING UNILETS, EXPLOSION-PROOF, DUST-IGNITION-PROOF FOR USE IN VERTICAL CONDUIT RUNS.

EYSF AND EYSM SERIES 1/2" TO 4" EYS 1/2" TO 1"

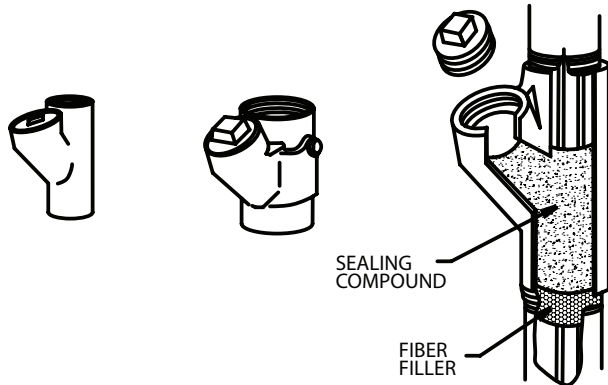

1. Install Unilet and pull conductors through.
2. Remove the large pipe plug. Tighten the small pipe plug on side of 3" and 4" Unilet sizes.
3. Dam the lower hub opening with Fiber Filler. (Page 1, Steps 1 & 2)
4. Mix sealing cement with the correct proportion of water per instructions provided with the cement. (Page 1, Step 3).
5. Pour Sealing Cement mixture into the Unilet opening until the cement is level with the last thread.
6. Replace and tighten pipe plug.

EYD SERIES 1-1/4" TO 4" EYDM SERIES 1-1/4" TO 4"

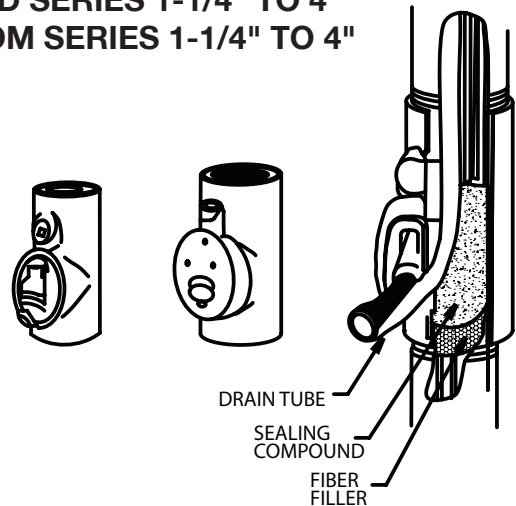

1. Install Unilet and pull conductors through.
2. Remove the large threaded cover from the Unilet.
3. Dam the lower hub opening with fiber filler. (Page 1, Step 2).
4. Replace the large threaded cover so that the threaded hole is facing downward.
5. Insert the tube and wire drain core into the opening of the large threaded cover so that the end being inserted will be above the compound in a completed seal. (See illustration above).
6. Be sure that the tube and wire drain core do not touch any of the conductors, Otherwise, this will expose the conductors in the completed and hardened seal. (See illustration above).
7. Mix Sealing Cement with the correct proportion of water per instructions provided with the cement. (Page 1, Step 3).
8. Pour Sealing Cement mixture into the Unilet through the opening located above the large cover until the last thread is covered with cement.
9. After cement has cured, (See page 1, "Caution: Temperature / Cure Time") pull out the old tube and wire drain core and discard.
10. Thread the small pipe plug into this opening and tighten .
11. Thread ECDB drain-breather fitting into large cover threaded hole and tighten secure.

SEALING UNILETS EXPLOSION PROOF, DUST IGNITION PROOF FOR USE IN VERTICAL AND/OR HORIZONTAL CONDUIT RUNS

EYS, EYF AND EYM SERIES 1/2" TO 6"

VERTICAL CONDUIT

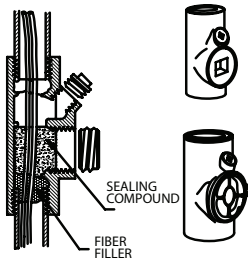

HORIZONTAL CONDUIT

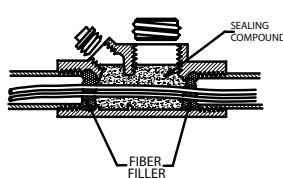

NOTE: On sizes 3-1/2" and 6" the cover should be tightened down with the small pipe plug removed from it. This will allow excess cement or air to escape out rather than seeping through or pushing the dam into the conduit. When the large cover has been tightened fully, replace pipe plug.

Vertical conduit

1. Install Unilet and pull conductors through.
2. Remove the pipe plug where the cement will be poured through and the large pipe plug or cover with the small pipe plug for size 3-1/2"-6" at the center of the Unilet.
3. Dam the lower hub with fiber filler. (Page 1, Steps 1 & 2.)
4. Replace the large pipe plug or cover with the small pipe plug for 3-1/2" thru 6" and tighten all threaded joints securely.
5. Mix Sealing Cement with the correct proportion of water per instructions provided with the cement. (Page 1, Step 3).
6. Pour Sealing Cement mixture into the small pipe plug opening until the cement is level with the last thread of the opening.
7. Replace and tighten small pipe plug.

Horizontal conduit

1. Install Unilet and pull conductors through.
2. Remove all pipe plugs and / or cover from the Unilet.
3. Dam both hubs with fiber filler. (Page 1, Steps 1 & 2)
4. Mix Sealing Cement with the correct proportion of water per instructions provided with the cement. (Page 1, Step 3).
5. Pour Sealing Cement mixture into the Unilet through the large opening until 2-3 threads are covered with the cement. Fill hole must be oriented in the upright position.
6. Replace and tighten in sequence the large pipe plug or cover, the small pipe plug into the Unilet and the small pipe plug into the cover.

ESUF AND ESUM SERIES 1/2" TO 1"

VERTICAL CONDUIT

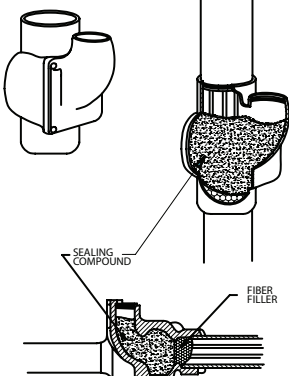

HORIZONTAL CONDUIT

Vertical Conduit

1. Install Unilet and pull conductors through.
2. Remove flanged cover and the pipe plug from the Unilet.
3. Dam the lower hub opening with fiber filler (Page 1, Steps 1 & 2).
4. Replace the flanged cover.
5. Mix Sealing Cement with the correct proportion of water per instructions provided with the cement (Page 1, Step 3).

6. Pour Sealing Cement mixture into the flanged cover opening until the cement level is equal to the last thread of the opening
7. Replace and tighten the small pipe plug.

Horizontal Conduit

1. Install Unilet and pull conductors through.
2. Remove the flanged cover.
3. Dam both hub openings with fiber filler (Page 1, Steps 1 & 2).
4. Mix Sealing Cement with the correct proportion of water -- per instructions provided with the cement. (Page 1, Step 3).
5. Pour Sealing Cement mixture into the Unilet opening until the cement level is equal to the bottom of the cover mounting flange. Fill hole must be oriented in the upright position.
6. Replace the flanged cover, tighten the small pipe plug.

EYD AND EYDM SERIES 1/2" TO 1" DRAIN AND SEALING UNILETS EXPLOSION-PROOF, DUST-IGNITION-PROOF FOR USE IN VERTICAL CONDUIT RUNS

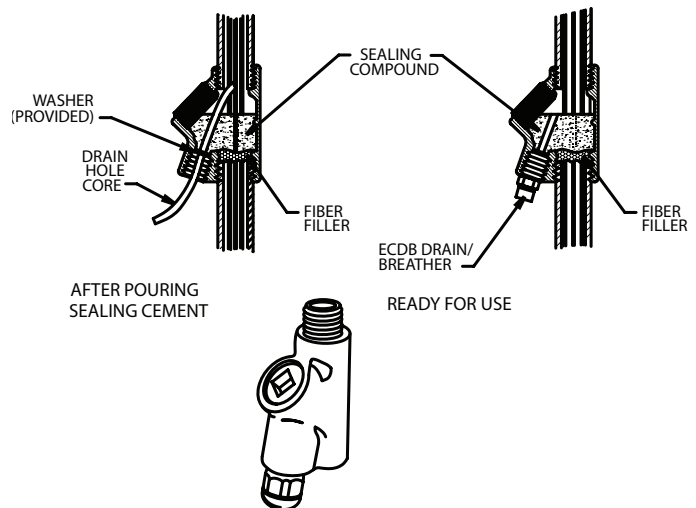

1. Install Unilet and pull conductors through.
2. Remove the pipe plug.
3. Dam the lower hub opening with fiber filler (See page 1, Steps 1 and 2).
4. Insert rubber drain-hole core through drain opening and washer (provided) high enough so inner end of core will be above sealing compound in completed seal.

Note: Washer (provided) must be inserted to last thread to form dam for sealing compound.

5. Be sure that the rubber drain - hole - core does not touch any of the conductors.
6. Mix Sealing Cement with the correct proportion of water per instructions provided with the cement (Page 1 Step 3.).
7. Pour Sealing Cement mixture into the Unilet opening until the cement is level with the last thread of the opening.
8. Replace and tighten pipe plug.
9. When cement has cured (see page 1, "Caution: Temperature / Cure Time") remove drain - hole - core.
10. Thread ECDB drain - breather fitting into threaded hole and tighten securely.

TABLE 1

THE MAXIMUM NUMBER OF CONDUCTORS THAT CAN BE SEALED IN A SEALING FITTING

- The maximum number of No. 4 Type THHN Conductors (Column B) in a 1-1/2" size sealing fitting is 6.
- The six (6) No. 4 THHN conductors represent the maximum wire fill of 25% or less for sealing fittings.
- Increasing the sealing fitting to a 2" trade size will provide space for the 40% wire fill, or nine (9) No. 4 conductors.

Example On How To Use Table 1

Trade Size	Conductor Size	Type	Max. No. Permitted For 25% Fill	Max. No. Permitted For 40% Fill/Trade Size Sealing Fitting Needed
1-1/2"	No.4	THHN (Col.B)	6	(9/2")

The Maximum number of wires that can be sealed in a fitting are as follows:

In our example, use an EYM / EYF200 for 2" size EYSF / ESUM, EYD, EYDM,

Size AWG or Kcmil	1/2" Seal (Qty/NPT Size)		3/4" Seal (Qty/NPT Size)		1" Seal (Qty/NPT Size)		1-1/4" Seal (Qty/NPT Size)		1-1/2" Seal (Qty/NPT Size)		2" Seal (Qty/NPT Size)		2-1/2" Seal (Qty/NPT Size)		3" Seal (Qty/NPT Size)		3-1/2" Seal (Qty/NPT Size)		4" Seal (Qty/NPT Size)		5" Seal (Qty/NPT Size)		6" Seal (Qty/NPT Size)			
	A	B	A	B	A	B	A	B	A	B	A	B	A	B	A	B	A	B	A	B	A	B	A	B		
18	7	11	12	20	20	33	35	58	49	80	80	131	115	187	176											
16	6	9	10	16	17	27	30	47	41	64	68	106	98	151	150											
14	3	8 (13 3/4")	6	15 (24 1")	10	24 (39 1 1/4")	18	43 (69 2")	25	58 (94 2")	41	96 (154 3")	58	137	90		121		155							
12	3	6 (10 3/4")	5	11 (18 1")	8 (9 1 1/4")	18 (29 1 1/4")	15	32 (51 2")	21	43 (70 2")	34 (35 2 1/2")	71 (114 3")	50	102 (164 3 1/2")	76 (77 3-1/2")		103		132							
10	1 (2-3/4")	4 (6 3/4")	4	7 (11 1")	7	11 (16 1 1/4")	13	20 (32 2")	17 (18 2")	27 (44 2")	29	45 (73 3")	41	65 (104 3 1/2")	64	100 (160 4")	86	134	110	172	173					
8	1	2 (3 3/4")	2	4 (5 1")	4	6 (9 1 1/4")	7	11 (16 1 1/2")	9	16 (22 2")	16	26 (36 2 1/2")	22	37 (51 3")	35	58 (79 4")	47	78 (106 5")	60	100 (136 5")	94	157	137			
6	1	1	1	2 (4 1")	2	4 (6 1 1/4")	4 (5 1 1/2")	7 (11 2")	6	9 (15 2")	10	16 (26 3")	15	23 (37 3 1/2")	23 (24 3 1/2")	35 (57 4")	32	47 (76 5")	41	61 (98 6")	64	96	93	139		
4	1	1	1	1 (2 1")	1	2 (4 1 1/4")	3	4 (7 2")	5	6 (9 2")	8	9 (16 3")	12	14 (22 3 1/2")	18	21 (35 4")	24	29 (47 5")	31	37 (60 6")	49 (50 6")	59	72	85		
3			1	1	1	2 (3 1-1/4")	3	3 (6 2")	4	5 (6 2")	7	8 (13 3")	10	12 (19 3 1/2")	16	18 (29 4")	21 (22 4")	24 (39 5")	28	31 (51 6")	44	50	63	72		
2			1	1	1	1 (3 1 1/4")	3	3 (5 2")	3 (4 2")	4 (7 2")	6	7 (11 3")	9	10 (16 3 1/2")	14	15 (25 4")	1/9	20 (33 5")	24	26 (43 6")	38	42	55	61		
1			1	1	1	1	2 (3 1 1/2")	3	3 (5 2")	4 (5 2 1/2")	5 (8 3")	7	7 (12 3 1/2")	10 (11 3-1/2")	10	11 (18 4")	14	15 (25 5")	18	20 (32 6")	29	31	42	45		
1/0			1		1	1	2 (3 2")	2	2 (4 2")	4	4 (7 3")	6	6 (10 3 1/2")	9	9 (15 4")	12	13 (21 5")	16	16 (27 6")	25	26	37	38			
2/0					1	1	1 (2 1 1/2")	1	2 (3 2")	3	3 (6 3")	5	5 (8 3")	8	8 (13 4")	11	11 (17 5")	14	14 (22 5")	22	22	32	32			
3/0					1	1	1	1	1 (3 2")	3	3 (5 3")	4	4 (7 3)	7	7 (11 4")	9	9 (14 5")	12	12 (18 5")	19	19	27	27			
4/0					1	1	1	1	1 (2 2")	2	2 (4 3")	3 (4 3")	3 (6 3")	6	6 (9 4")	8	8 (12 5")	10	10 (15 5")	16	16	23	23			
250							1	1	1	1	2 (3 2 1/2")	3	3 (4 3")	5	5 (7 4")	6	6 (10 5")	8	8 (12 5")	13	13	19	19			
300							1	1	1	1	1 (3 2 1/2")	3	3 (4 3")	4	4 (6 4")	5	5 (8 5")	7	7 (11 5")	11	11	16	16			
350							1	1	1	1	1 (2 2 1/2")	1 (2 3")	2 (3 3")	3 (4 3-1/2")	5	5 (7 5")	6	6 (9 5")	10	10 (15 6")	15	15				
400							1	1	1	1	1	1	2 (3 3")	3	3 (5 4")	4	4 (6 4")	6	6 (8 5")	9	9 (13 6")	13	13			
500							1	1	1	1	1	1	1 (2 3")	3	3 (4 3 1/2")	4	4 (5 4")	5	5 (7 5")	8	8 (11 6")	11	11			
600									1	1	1	1	1 (2 3-1/2")	2 (3 3 1/2")	3	3 (4 4")	4	4 (5 5")	6	6 (9 6")	9	9				
700									1	1	1	1	1	1	2 (3 3 1/2")	3	3 (4 5")	4	4 (5 5")	6	6 (8 6")	8	8			
750									1	1	1	1	1	1	1 (2 3 1/2")	3	3	3	3 (4 5")	5	5 (7 6")	8	8			
800									1	1	1	1	1	1	1	2	2	3	3	5	5	7	7			
900									1	1	1	1	1	1	1	1	2	3	3	4	4	7	7			
1000											1	1	1	1	1	1	1	1	3	3	4	4	6	6		
1250												1	1	1	1	1	1	1	2	3	3	5	5			
1500													1	1	1	1	1	1	1	3	3	4	4			
1750														1	1	1	1	1	1	2	2	4	4			
2000															1	1	1	1	1	1	1	3	3			

* COL. A = Wire Types: RFH-2, RH, RHH, THW, TH, XHHW (AWG 14-6).

COL. B = FEP, THHN, THWN, TFN, PF, PGFF, XHHW (AWG4-2000 MCM), FEPBV (AWG 14-8).

NOTE: For all other conductor sizes and types, wire fill is based on maximum 40% fill or less depending on conduit size and conductor type per the NEC Code.

• For all other conductor sizes and types, wire fill is based on maximum 25% fill or less.